

Rasonic 樂信牌

抽濕機 Dehumidifier

RPD-YG20U

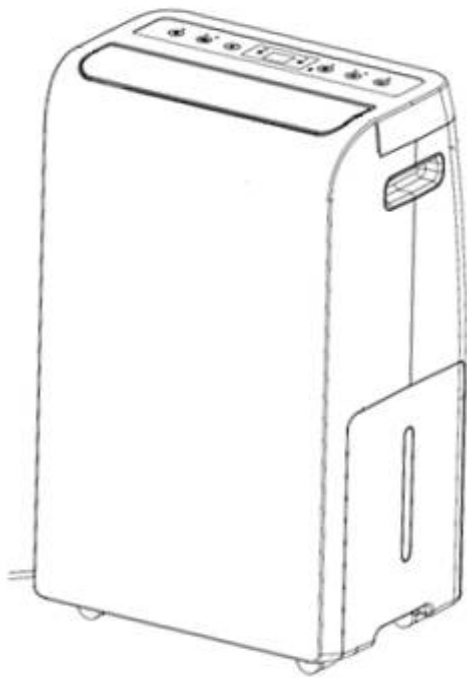

目錄 Content

一 安全注意事項-----	1-3
二 使用環境-----	4
三 產品結構-----	5
四 清潔與保養-----	5-6
五 使用方法和控制功能-----	6-11
六 故障排解-----	12-13
七 特別聲明-----	13
八 售後服務-----	14
九 產品規格-----	14
1. Safety Precautions-----	15-17
2. Operating Condition-----	18
3. Product Structure-----	19
4. Cleaning and Maintenance-----	19-20
5. Operating Introduction -----	20-24
6. Troubleshooting-----	25-26
7. Special Avowal-----	26
8. After Sales Services-----	27
9. Product Specification-----	27

使用說明書

Instruction Manual

- 使用前，請仔細閱讀本說明書，並保存以便日後參考。

Please read this instruction manual before using the product and retain it for your future reference.

- 本說明書中所有的圖片僅供參考。

All the pictures in the manual are for reference only.

一 安全注意事項



在使用本機之前，務必詳細閱讀此說明書，並妥善保管，以便日後參考使用！

- 1) 不遵循或忽視這些安全注意事項會導致火災、觸電或個人傷害。
- 2) 使用本機前，先核對供電電壓是否與本機相符。
- 3) 抽濕機為耗電量大的電器，應獨立接駁到一個固定插座，避免使用拖板或在同一個插座上插上其他電器，以免負荷過重導致起火或觸電。
- 4) 不要在窗邊或浴室使用，否則可能會導致觸電。
- 5) 不要將機器放置在能產生高溫家電附近，因為高溫可能損壞塑膠及引起火災；也不要將機器在陽光下暴曬，以免外殼變形、變色。



- 6) 不要在塵埃較大或有腐蝕性氣體，爆炸性氣體的場所使用，以免發生危險。
- 7) 如與兒童一起使用，應給予適當的指導。不要試圖拆卸本機，以免發生危險。如發現抽濕機有損壞、不尋常的聲音、異味或震動時，應聯絡信興電器服務中心有限公司進行檢查及維修。
- 8) 把機器放在一個穩固，平坦的地面上使用，以防止產生震動和噪音。
- 9) 一旦機器傾倒，應立即拔掉電源插頭。
- 10) 機器運行時，不可覆蓋出風口，以免機器發生故障。

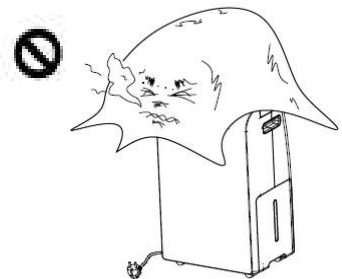
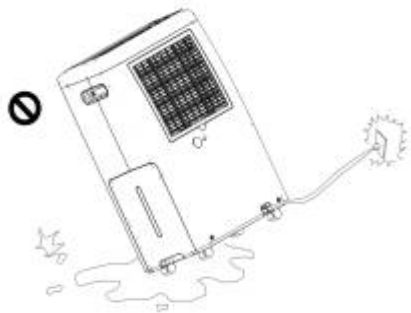

- 11) 不要阻擋進風口或出風口的空氣流動，以防止影響抽濕機性能或產生故障。本設備使用時各面距離牆或者其他障礙物的安全距離是 30cm。切勿把抽濕機置於狹窄的空間，例如衣櫃內使用，通風不良可能導致發熱及起火。
- 12) 不要直接噴水到機體上清洗，以免引起機器故障和觸電。
- 13) 手濕不要拔電源，以免觸電。



- 14) 拔出電源線插頭前要先關機，以免出現觸電或其他危險。
- 15) 若長時間不使用，應關機並拔掉電源線插頭，然後倒掉水箱裡的水並擦拭乾淨。

- 16) 不要用力拉扯電源線，以免損壞電源線及造成其他危險。



- 17) 機器運行時，禁止將手指或其他物件插入進風口或出風口內，以防止損壞機器或造成受傷。
- 18) 移動機器時，先拔出插頭及將水箱中的水倒掉，以免水濺出。

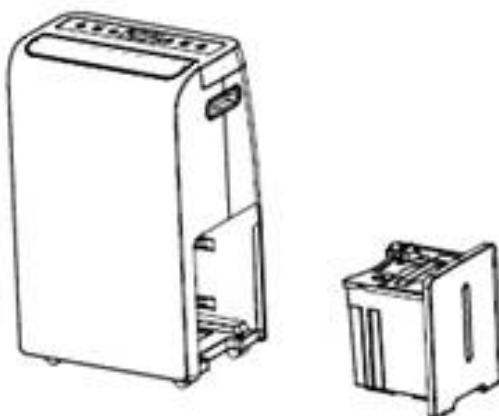

- 19) 在有人監督或根據安全使用設備說明之指示下，此設備可由 8 歲以上的兒童和體質、感覺或心智能力不足或是缺乏經驗與知識人士使用，但他們須了解其相關的風險。兒童不應擅自使用設備。不應由兒童獨自進行清潔與進行保養。
- 20) 此抽濕機不可由體質、感覺或心智能力有障礙或是缺乏經驗與知識人士(包括兒童)使用，除非有負責其安全之人士的監督或是提供相關使用設備指示的情形下使用。
- 21) 若電源線受損，為避免危險，必須由信興電器服務中心有限公司進行更換。
- 22) 如抽濕機有一段長時間沒有使用，必須先檢查後才可使用。
- 23) 切勿連接過壓電源或超負荷使用插座或拖板，否則可能引致電擊或設備過熱而導致火災。
- 24) 切勿擅自拆卸或自行維修，否則可能會損壞機器或引致電擊。
- 25) 清潔產品前，須關閉電源並拔出插頭，否則將會引致電擊或造成傷害。
- 26) 切勿飲用或使用回收水。回收水含有害物質會危害您的身體健康。
- 27) 機器在運行過程中嚴禁拉出水箱，否則會引起水滿保護和電擊。
- 28) 將機器放置在穩固水平地面上，假如機器傾倒會使回收水溢出，從而損壞物件、引致電擊或發生火災。
- 29) 切勿將衣服、毛巾或任何物品遮擋抽濕機進風口或排氣口，通風不流暢會導致過熱而引發火災。
- 30) 使用本產品時，需特別注意嬰幼兒、兒童、老人及對空氣濕度不敏感之人士。
- 31) 切勿在有化學物質的環境下使用本產品，否則揮發在空氣中的化學氣體及溶劑會降低機器的性能。
- 32) 切勿在電源線上放置重物或壓縮電源線，否則將會引致電擊或者引發火災。
- 33) 切勿在機器上放置花瓶或其他液體容器，否則液體可能會進入機器內部，導致絕緣失效及觸電或火災。
- 34) 必須正確安裝空氣過濾網，並每兩周清洗一次。不安裝過濾網或灰塵堵塞會導致機器運作故障。
- 35) 當有水進入機器時，應即關機並拔出插頭，否則將會導致機器故障或者引發意外。
- 36) 切勿攀爬或坐於本產品上，否則產品倒下時會導致受傷。
- 37) 須確保機器正確接地，以減少被電擊和避免火災。
- 38) 切勿讓抽濕機在無人看管下運作。不使用抽濕機時，須拔掉插頭。

二 使用環境

1. 除濕工作環境：溫度 5°C - 35°C，相對濕度 30%RH - 90%RH
2. 本機只適合於室內環境使用，如客廳、臥室及辦公室等，切勿在室外使用。
3. 使用本機時，應確保所有門窗都已關閉，以達到最高效率及節能。
4. 將機器放置在穩固、平坦的地面上使用，以免導致過大的震動而產生噪音。機體不可傾斜放置，以免水溢出或機器傾倒。
5. 不可將抽濕機放在滴水的衣物下面使用。

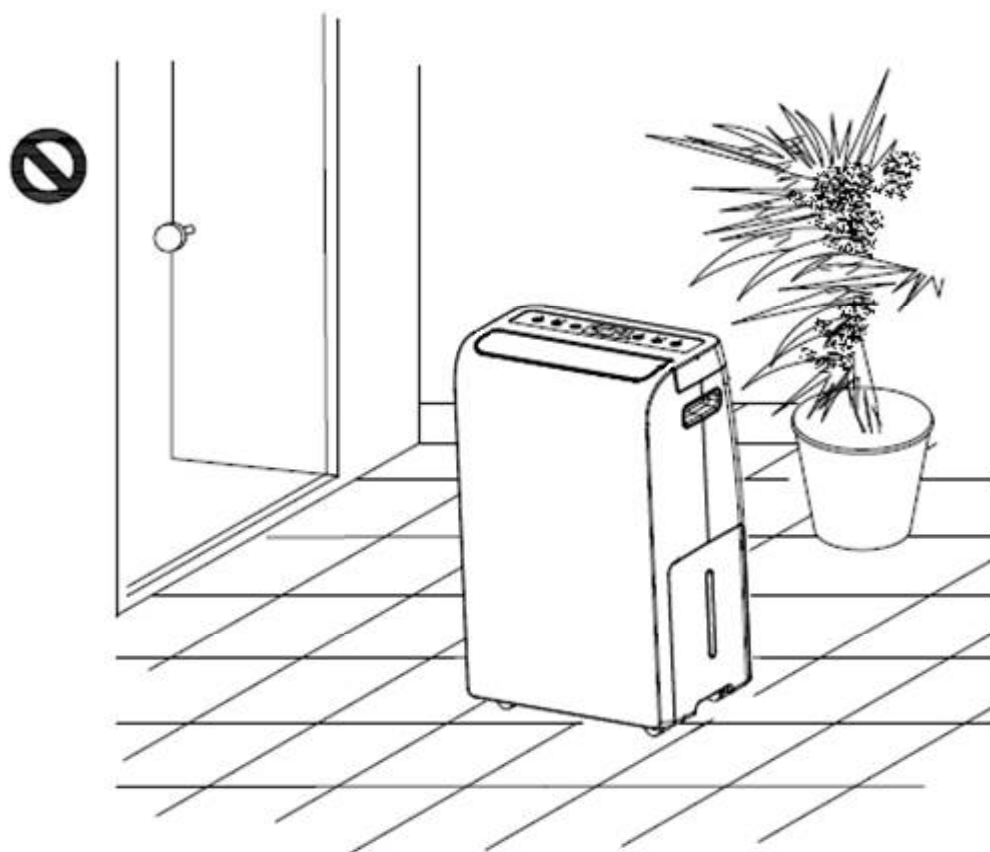

三 產品結構

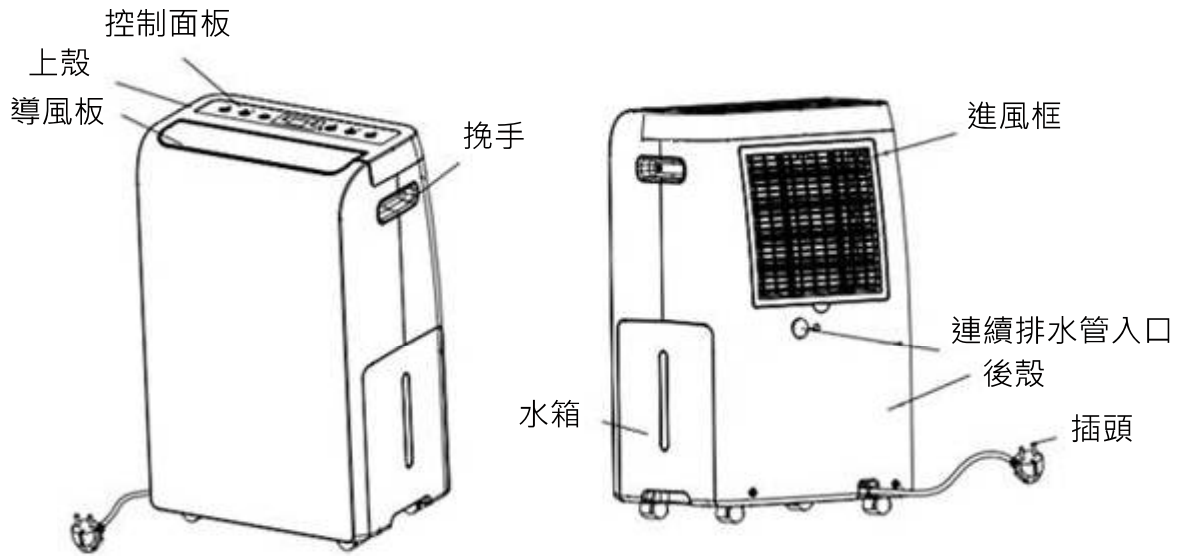

四 清潔與保養

注意：清潔保養前，務必關機並拔出電源插頭。以下為清潔抽濕機時的注意事項：

1. 清潔機器及進出風口

- * 使用清水及中性清潔劑，切勿使用有毒或含有腐蝕性的清潔劑。
- * 切勿將水灑在機器上，否則會引發短路、絕緣失效或零件鏽蝕。
- * 進出風口容易累積灰塵，可用吸塵器或毛刷進行清理。

2. 清理水箱

- * 每隔幾周清洗一次水箱，以防發霉及滋生細菌。
- * 取出水箱時，需輕拿輕放，清洗時可加入適量的中性清潔劑，均勻塗抹水箱內，然後用清水沖洗乾淨並抹乾。清洗完畢後，把水箱放回原位。

3. 清洗空氣過濾網

- * 空氣過濾網位於機器後面進風框處，應經常檢查及至少每 30 天清洗一次。
- * 如在灰塵多的環境中使用，則需加密清洗次數，防止因堵塞導致通風不暢而損壞機器。
- * 取出步驟：用手把進風框扣位向外拉出。
- * 裝回步驟：將進風框頂端的三個扣位對準機器上的扣位，在進風框底部兩個扣位處向內壓。

4. 清洗機身

* 請用柔軟而乾淨的布擦拭機身，並貯存於通風乾燥的環境下，不可使用酒精，汽油，稀釋劑或其他化學溶劑。





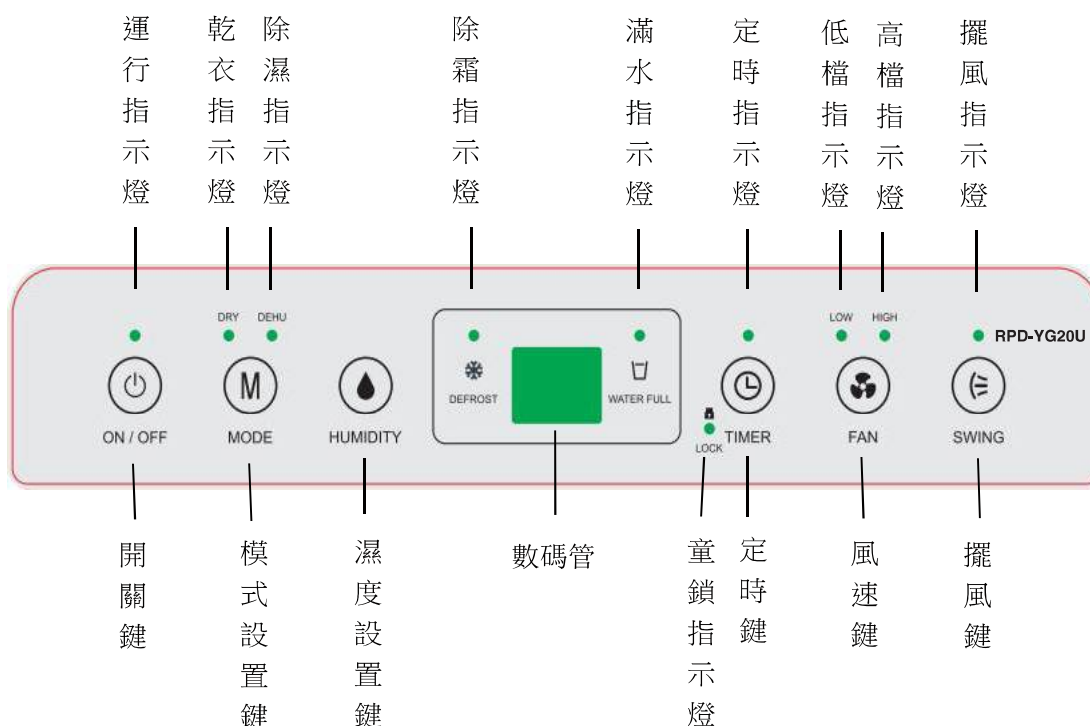

- 本產品外殼為塑膠製品，應避免陽光直接照射機身。
- 移動機體前，應關機並拔下插頭，將水箱中的水倒掉。
- 若長期不使用產品，應關機及拔掉插頭並將水箱的水全部倒掉。放置兩天，待機器內部乾燥後再包裝，保存於通風、乾燥的環境下，以延長抽濕機的使用壽命。貯存時，應將機體立放，切勿橫放和倒放。
- 如產品需要維修，應聯絡信興電器服務中心有限公司跟進，切勿擅自改裝產品或使用非原裝零件進行修理，否則可能造成危險及維修保養無效。

五 使用方法和控制功能

(一) 按鍵和顯示面板



(二) 按鍵名稱及功能

1.  開/關鍵 (ON/OFF): 按下此鍵可開、關抽濕機。
2.  模式鍵 (MODE): 按下此鍵可切換乾衣運行模式和除濕運行模式。
3.  濕度設定鍵 (HUMIDITY): 按下此鍵可設置抽濕機運行的濕度環境，數碼管顯示相應的濕度設定值。
4.  定時鍵/童鎖鍵(TIMER/LOCK): 按下此鍵可設置抽濕機定時關機時間，數碼管顯示相應的定時關機剩餘時間。長按定時鍵 3 秒，可開啟或關閉抽濕機的童鎖功能，在顯示面板上的童鎖指示燈會亮起或熄滅。
5.  風速鍵 (FAN): 按下此鍵可調節抽濕機的風速，可設置高/低檔兩個檔位的風速。風速設定之後，指示燈顯示設定的風速檔位。
6.  擺風鍵 (SWING): 按此鍵可開啟或關閉擺風功能。

(三) 按鍵操作/控制功能說明

1、開機：

接駁電源，按下開/關鍵 (ON/OFF)，抽濕機啟動運行，導風板自動打開。抽濕機預設除濕模式 (DEHU)，風速按高檔運行，但壓縮機在 3 分鐘後才會開始啟動運行。
如在關機後再開機，抽濕機會按關機前的運行狀態運行。

關機：

抽濕機在運行過程中，按下開、關鍵 (ON/OFF)，抽濕機停止工作。

2、模式設置：

按下模式鍵 (MODE)，可切換乾衣 (DRY) 和除濕 (DEHU) 兩種模式。

- ① 乾衣運行模式 (DRY): 乾衣指示燈點亮，抽濕機進行連續除濕，不可調節風速。
- ② 除濕運行模式 (DEHU): 除濕指示燈點亮，抽濕機在除濕運行模式運行。按下風速 (FAN) 鍵可調節風速。

3、濕度設定：

按下濕度設定鍵 (**HUMIDITY**)，可設置所期望的環境濕度值，**88** 數碼管顯示從 **CO**~40%~45%~50%~55%~60%~65~70%~**CO** 迴圈，完成濕度設定後，數碼管顯示由環境濕度設定值轉為顯示當前環境濕度值。

當抽濕機檢測到當前環境濕度比設定濕度值低 2%RH，抽濕機停止除濕，風速以低檔運行。當抽濕機檢測到當前環境濕度比設定濕度值高 2%RH，抽濕機啟動除濕，風速恢復為原設置風速檔運行。例如設定濕度為 50%，當抽濕機檢測到當前環境濕度 <48%RH 抽濕機停止除濕，風機在低檔運行。當抽濕機檢測到當前環境濕度 >52%RH，抽濕機啟動除濕，風機在設定風速檔運行。當環境濕度值 ≤30%RH 時會顯示 "LO"，環境濕度值 ≥80%RH 時會顯示 "HI"。

CO 表示為連續除濕，除濕運行不受環境濕度控制。抽濕機開機預設為連續除濕模式。

抽濕機在乾衣運行模式下，抽濕機以連續除濕模式運行。

4、定時關機：

按下定時鍵 (**TIMER**)，可設置抽濕機定時關機時間，定時指示燈點亮，數碼管顯示從 **0H**~1H~2H~3H~4H~5H~6H~7H~8H~**0H** 迴圈。數碼管顯示 "0H"，表示解除定時設定，即沒有設置定時關機，定時指示燈熄滅。定時功能生效後，重新按下定時鍵會顯示預設定時剩餘時間，從而清楚顯示抽濕機尚餘運行時間。

在定時設定中，如果抽濕機水箱滿水或者處於除霜狀態，定時時間設定仍然有效，直到定時時間完結後，抽濕機自動關機，整機停止工作。

5、風速設置：

按下風速設置鍵 (**FAN**)，可調節抽濕機的風速高低，可設置高和低兩個檔位。設置風速時，相應的風速檔位指示燈 (高或低) 會點亮。

(註：在乾衣運行模式時不能設置風速。)

6、擺風：

按下擺風鍵 (**SWING**)，可開啟、關閉擺風功能，開啟時擺風功能指示燈點亮。擺風開啟時導風板作上下方向擺風運行。

7、童鎖功能：

在機器運行中，按下定時鍵 (TIMER) 3 秒，機器童鎖功能啟動，圖示 (LOCK) 點亮，再按其他鍵均不起作用。

再按下定時鍵 (TIMER) 3 秒或拔掉電源插頭機器斷電後，才能解除童鎖功能。

8、負離子功能：

機器開機運行時負離子功能自動開啟，機器關機時負離子功能自動關閉。

(四) 記憶功能

(1) 關機後再重新開機，抽濕機會按關機前設定模式運行。

注意：定時和童鎖功能不能應用記憶功能。

(2) 抽濕機在運行時如意外地斷電或拔掉電源插頭，當再次接上電源後，不需再按開/關鍵便會自動運行並回復到斷電前的工作模式。

(五) 滿水自動停機功能

當機器檢測到水箱水位達到設定高度，蜂鳴器將發出警報，滿水指示燈  點亮，同時整機停止運行，導風板自動關閉。取出水箱，將水倒掉，再放回水箱，機器將按滿水前的設置狀態重新開機運行 (注意：當放回水箱後，壓縮機會待 3 分鐘後才會開始運作，以保護壓縮機)。

(六) 自動除霜功能

當抽濕機於低溫環境運作時，為保護製冷系統，自動除霜功能會啟動。若溫度感應器感應到蒸發器的銅管溫度低於或等於 -1°C 時，壓縮機連續工作 30 分鐘後停止，機器進行除霜，此時除霜指示燈  在點亮。待溫度感應器感應到蒸發器的銅管溫度高於或等於 2°C ，和機器除霜時間多於或等於 10 分鐘，壓縮機才能啟動運作，然後機器開始除濕，並且除霜指示燈  熄滅。

(七) 壓縮機延時啟動功能

壓縮機停止後，如果立即再起動，因製冷系統壓力未平衡，容易啟動機器超載保護功能。因壓縮機設有延時 3 分鐘啟動功能，開機後壓縮機會延時 3 分鐘後啟動。

(八) 超溫安全保護功能

機器檢測到環境溫度 $< 3^{\circ}\text{C}$ 或 $> 40^{\circ}\text{C}$ ，機器停止除濕運行，風機仍維持原來的風速設置運轉。機器檢測到環境溫度 $\geq 5^{\circ}\text{C}$ 或 $\leq 38^{\circ}\text{C}$ ，機器恢復除濕運行（壓縮機再啟動時需達到延時 3 分鐘啟動的保護時間）。

(九) 低濕度安全保護功能

機器檢測到環境濕度 $\leq 30\%RH$ 時，數碼管顯示 "LO"，機器停止除濕運行，風機按超低檔運轉。機器檢測到環境濕度 $> 35\%RH$ ，數碼管顯示實際濕度，機器恢復除濕運行（壓縮機再啟動時需達到延時 3 分鐘啟動的保護時間）。

機器檢測到濕度 $> 80\%RH$ 時，數碼管顯示 "HI"，機器保持設定運行狀態。

(十) 高溫下強制風機轉速轉換功能

抽濕機在高溫環境下除濕運行，低風速檔運行會令壓縮機負載加重，故高溫環境下除濕時，機器會自動將低速檔切換到高風速，待環境溫度下降後，再恢復原來設置的檔位運行。

(十一) 連續排水功能

當抽濕機需連續排水時，移開後殼的排水孔塞頭，用一根內徑 15mm 軟膠管通過後殼排水孔連接到排水孔上，機器連續運行，水箱不會盛水。此時機器可連續運行而不會因水箱水滿而導致停機保護。

連續排水時，排水管需平放於地面。排水管的任何部位不可有折疊和上翹現象存在，否則可能會產生排水不順，甚至不排水的情形。

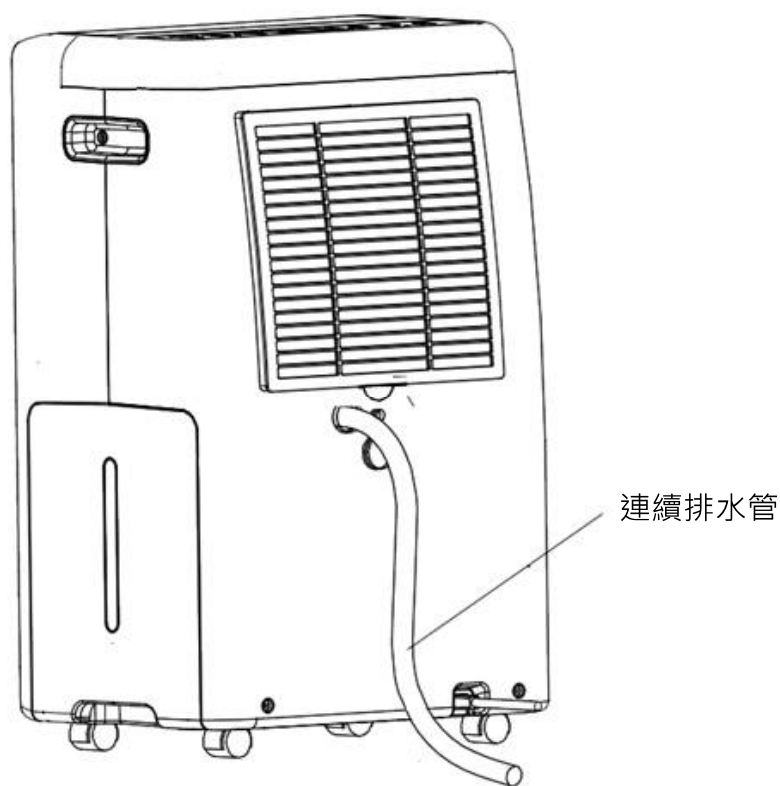

六 故障排解

在要求售後服務前可先行查閱下表。

問題	待檢查事項
抽濕機無法啟動	<ul style="list-style-type: none"> <input type="checkbox"/> 確認抽濕機插頭完整插入插座中。 <input type="checkbox"/> 屋內無熔絲開關或保險絲是否斷掉？ <input type="checkbox"/> 環境已達至預定濕度或是水箱已滿。 <input type="checkbox"/> 水箱未有安放在正確位置。
抽濕機效能未如理想	<ul style="list-style-type: none"> <input type="checkbox"/> 沒有足夠時間移除濕氣。 <input type="checkbox"/> 確認沒有窗簾、百葉窗或是家具堵塞抽濕機前方或後方。 <input type="checkbox"/> 環境濕度比設定的低。 <input type="checkbox"/> 確認所有門、窗及其他開口處都已穩固關上。 <input type="checkbox"/> 室溫過低，低於 5°C (41°F) <input type="checkbox"/> 有煤油暖氣或是其他設備於室內散發水蒸氣。
裝置運作有巨大噪音	<ul style="list-style-type: none"> <input type="checkbox"/> 空氣過濾網堵塞。 <input type="checkbox"/> 裝置傾斜而非擺放平穩。 <input type="checkbox"/> 放置的位置非水平。
蒸發器結霜	<ul style="list-style-type: none"> <input type="checkbox"/> 此為正常。抽濕機隨後會啟動自動除霜功能。
漏水	<ul style="list-style-type: none"> <input type="checkbox"/> 水管與接頭或是水管接點可能鬆動。 <input type="checkbox"/> 設計是使用水箱集水，但背面排水孔塞頭可能被移除。
顯示器中出現錯誤代碼	C1 <ul style="list-style-type: none"> <input type="checkbox"/> 除霜溫度傳感器可能開路、短路，拔出裝置插頭然後再次插上。 <input type="checkbox"/> 蒸發器溫度 $\geq 40^{\circ}\text{C}$ <input type="checkbox"/> 若持續發生錯誤，應聯絡信興電器服

		務中心有限公司進行檢查及維修。
	C2	<input type="checkbox"/> 環境溫度傳感器可能開路、短路，拔出裝置插頭然後再次插上。 <input type="checkbox"/> 溫濕度感應電路板故障，拔出裝置插頭然後再次插上。 <input type="checkbox"/> 環境溫度 $\leq 0^{\circ}\text{C}$ / $\geq 40^{\circ}\text{C}$ <input type="checkbox"/> 若持續發生錯誤，應聯絡信興電器服務中心有限公司進行檢查及維修。
	C8	<input type="checkbox"/> 裝置偵測到雪種泄漏，應聯絡信興電器服務中心有限公司進行檢查及維修。

如遵從以上方法處理仍然無法解決問題，應立即停止使用並聯絡信興電器服務中心有限公司進行檢查及維修。

七 特別聲明

1. 本資料上所有內容經過認真核對，如有任何印刷及內容上的誤解，本公司將保留解釋權。
2. 本產品若有技術改進，會編進新版說明書中，恕不另行通知；產品外觀及顏色如有改動，則以實物為準。
3. 使用說明書的電子副本可以通過電子郵件發送致客戶。如有需要，請致電信興電工工程有限公司：2861 2767。

八 售後服務

由購買日期起之一年保修期內，經信興電器服務中心有限公司之服務人員證實乃在正常使用之情況下發生者，本公司將提供免費修理及更換零件。經更換之任何損壞零件，將歸屬本公司。保修範圍不包括修理或更換產品之附件、外接線、水箱或機殼等，如有需要服務時，用戶須另付費用。

用戶請於維修時出示購買收據 / 換購收據及保修證，如有任何疑問，請致電信興電器服務中心有限公司熱線查詢：2406 5666。

如在保修證內所列之電器：1)曾經被非本公司技術人員明顯地或非明顯地進行改裝、更改或修理；或 2)曾經被錯誤或不適當或疏忽使用、或因液體浸蝕、水濺、不正常供電、天災、意外或外來因素造成損壞；或 3)並非安裝在陸上固定地點；或 4)不當安裝位置影響正常操作；或 5)非工商業用型號產品，被用作工商業用途；或 6)用戶搬遷地址或更換物主而未能及時通知信興電器服務中心有限公司者，本保修證將自動失效。

九 產品規格

型號	RPD-YG20U
額定電壓及頻率	220-240V 伏特 ~ 50 赫茲
抽濕量	23 公升/每日 (30°C · 80%RH)
	13 公升/每日 (26.7°C · 60%RH)
消耗功率	220 瓦 (26.7°C · 60%RH)
額定功率	295 瓦 (35.0°C · 90%RH)
製冷劑	R134a/150 克
水箱容量	3.8 升
尺寸規格 (闊 x 深 x 高)	355×252×567 毫米

1. Safety Precautions



Do not operate the unit before carefully reading this instruction manual. Please keep this manual for future reference.

- 1) Failure or negligence in observing these safety precautions could cause fire, electric shock or personal injury.
- 2) Please be sure your electricity is correct.
- 3) Use an independent socket for the appliance. Do not use extension cords to avoid overload and risk of fire and electric shock.
- 4) Please do not place the device near window or in bathroom to prevent electrical shock.
- 5) Please ensure the unit is not placed closely to the high temperature appliance to prevent plastic destroying and fire. Do not use in places exposed to direct sunlight to avoid deform and discolor.



- 6) Never operate this unit in a flammable explosive, corrosive or dusty atmosphere to avoid hazard.
- 7) Always provide guidance if children operate this unit. Never disassemble the unit to avoid hazard, if damage, odor, abnormal sound or vibration are found, please call Shun Hing Electric Service Centre Ltd. to check and repair the dehumidifier.
- 8) Operate this unit on a stable and flat surface to avoid vibration and noise.

9) If the unit toppled over, please pull out the plug at once.

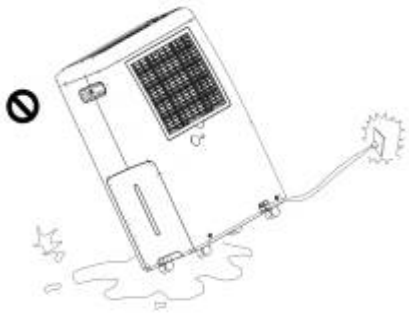

10) Make sure outlet ventilation is not blocked at all times.

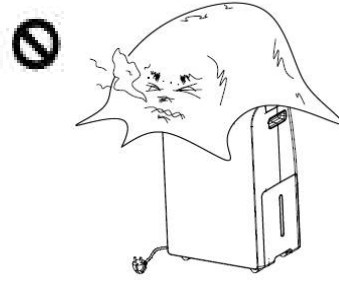

11) Ensure air intake and air outlet ventilation is not blocked at all times. Ensure there is 30 cm of clear space on all sides of the unit. Do not operate the appliance in narrow space such as wardrobes or cabinet. Poor ventilation may result in heat and fire.

12) Do not spray water on the unit, spraying water may cause malfunctioning and electric shock.

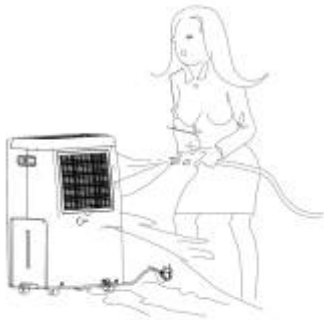

13) Never pull the socket by using damp hands, otherwise, it may cause electric shock.



14) Always switch off the appliance before unplugging to avoid electric shock or other hazards.

15) Switch off and unplug the unit, empty and clean the water tank when not using the unit for a long time.

16) Do not pull power cord by force because it will cause damage to power cord and cause other hazard.



17) Never put fingers or other objects in any openings of the unit to avoid injury and product damage.

18) You must pay attention when moving the unit, empty the water tank and unplug the appliance before moving to prevent water spillage.

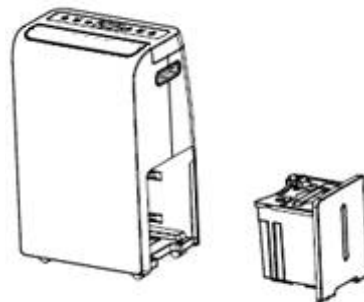

- 19) This appliance can be used by children aged from 8 years and above and persons with reduced physical, sensory or mental capabilities or lack of experience and knowledge if they have been given supervision or instruction concerning use of the appliance in a safe way and understand the hazards involved. Children shall not play the appliance. Cleaning and user maintenance shall not be made by children without supervision.
- 20) This appliance is not intended for use by persons (including children) with reduced physical, sensory or mental capabilities or lack of experience and knowledge, unless they have been given supervision or instruction concerning use of the appliance by a person responsible for their safety.
- 21) If the supply cord is damaged, it must be replaced by Shun Hing Electric Service Centre Ltd. in order to avoid hazard.
- 22) Check the appliance carefully before use if the dehumidifier is not used for a long time.
- 23) Do not exceed the rating of the power outlet or extension cord or connection device. Otherwise, it may cause electric shock or fire due to excess heat generation.
- 24) You should never try to disassemble or repair the unit by yourself. Otherwise, it may cause failure of machine or electric shock.
- 25) Before cleaning, turn off the power and unplug the unit. Otherwise, it may cause electric shock or injury.
- 26) Do not drink or use the water drained from the unit. It contains contaminants and could make you sick.
- 27) Do not take the water tank out during operation. Otherwise, it may trigger tank full protection of the unit and cause electric shock.
- 28) Place the unit on a stable and flat floor surface. If the unit falls over, it may cause the collected water to spill and damage belongings, or cause electrical shock or fire.
- 29) Do not cover the intake or exhaust openings with clothes, towels or other objects. Poor ventilation can lead to overheating and fire.
- 30) Care should be taken when using the unit in a room with the following persons: Infants, children, elderly people and people not sensitive to humidity.
- 31) Do not use in areas where chemicals are handled. This will cause the unit deterioration due to chemicals and solvents dissolved in the air.
- 32) Do not place heavy object on the power cord and pay attention that the cord is not compressed. There is danger of fire or electric shock.
- 33) Do not place flower vases or other water container on top of the unit. Water may spill inside the unit, causing insulation failure and electrical shock or fire.
- 34) Always insert the air filter securely. Clean filter once every two weeks. Operation without filter and dust clog may cause failure.
- 35) If water enters the unit, turn off the unit and disconnect the power immediately.

Otherwise, it may cause failure of appliance or accident.

- 36) Do not climb up on or sit on the unit. You may be injured if you fall or if the unit falls over.
- 37) Be sure the unit is properly grounded to minimize shock and fire hazards.
- 38) The dehumidifier must not be left unattended while it is connected to the supply main. Unplug when the appliance is not in use.

2. Operating Condition

1. Working condition: Ambient temperature: 5°C - 35°C
Ambient humidity: 30%RH-90%RH
2. This dehumidifier is only for indoor use, e.g. living room, bedroom, office etc. Never use it in outdoors.
3. For the best efficiency and energy saving, make sure the door and window are closed before switching on the unit.
4. Ensure that the unit is placed on a stable and flat floor surface to prevent excessive vibration and noise. If the appliance tilted, it may cause water overflow and machine overturn.
5. Never place the unit under the dripping clothes.

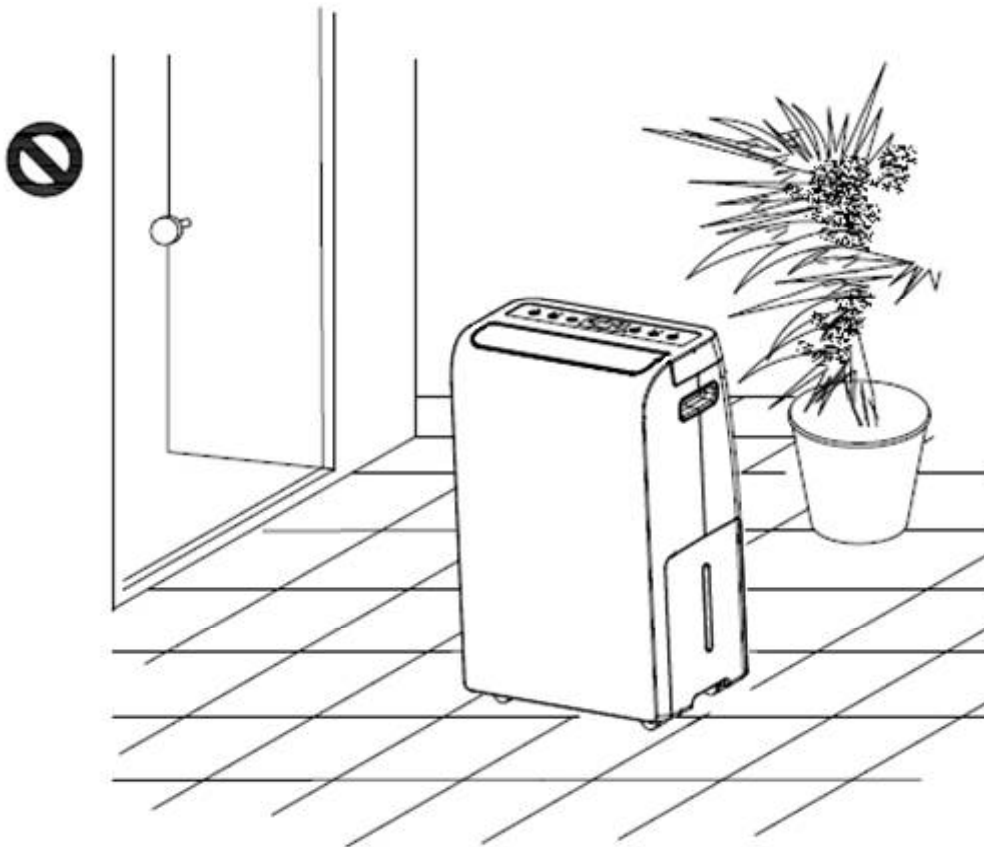

3. Product Structure

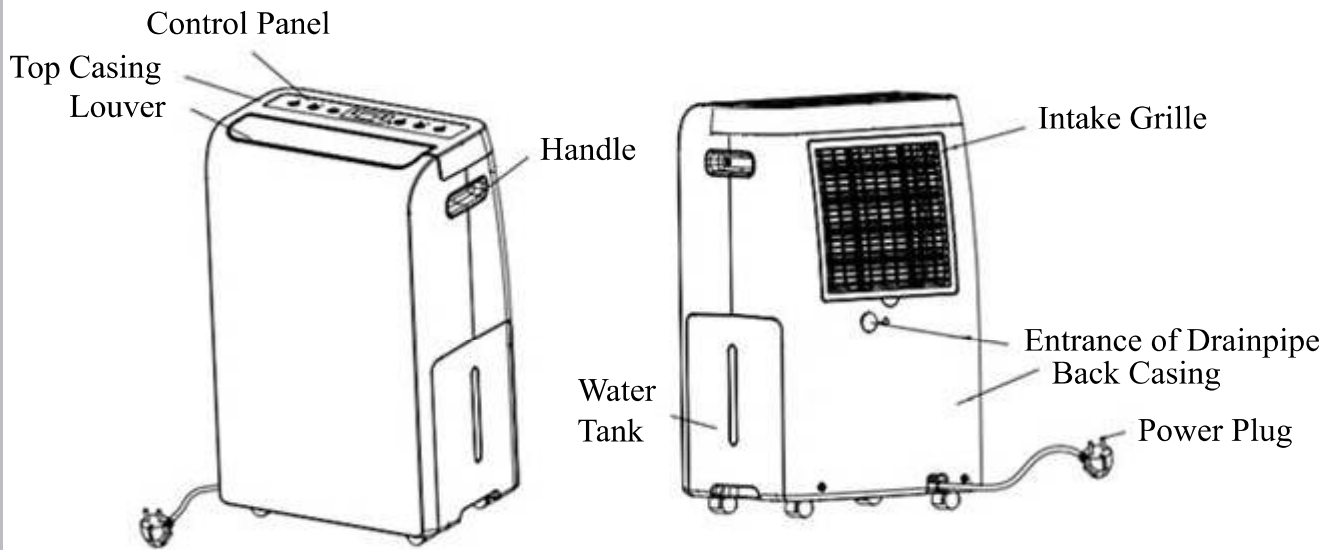

4. Cleaning and Maintenance

CAUTION: Make sure the dehumidifier is switched off and unplugged before cleaning. The following are precautions when cleaning the dehumidifier:

1. Clean the grille and case
 - * Use water and a mild detergent. Do not use poisonous or corrosive detergent.
 - * Do not splash water directly onto the main unit, otherwise, this may cause an electrical shock, the insulation to deteriorate or rusting.
 - * The air intake and outlet grilles get soiled easily, so use a vacuum cleaner or brush to clean.
2. Clean the water tank
 - * Clean the water tank to prevent growth of mold, mildew and bacteria in every few weeks.
 - * Take out the water tank carefully and add optimum amount of neutral or mild detergent into the tank with clean water. Swish it around in the water tank, then empty and rinse. Reinstall the water tank after cleaning.
3. Clean the air filter
 - * The air filter behind the intake grille should be checked and cleaned at least every 30 days or more often if necessary.
 - * If the machine is used in a dusty environment, the cleaning frequency should be increased to avoid dust blockage. Otherwise, this may damage the dehumidifier and cause poor ventilation.

- * Remove Procedure: Grip the tab on the intake grille and pull it outward.
- * Reinstall Procedure: Aim 3pcs tabs at the top of intake grille to the machine's slots, then press the 2pcs tabs at the bottom of intake grille.

4. Clean the unit casing



- * Only use a soft clean cloth for all cleaning purpose, and let the machine dry in a ventilated place. Do not use alcohol, gasoline, thinner or other chemicals.
- The casing of this machine is made of plastic, do not expose it in direct sunlight.
- Before moving the machine, please switch off, unplug the unit, and dispose water in the tank.
- If you do not use the unit for a long time, please switch off and unplug the unit, empty the water tank, and pack it after 2 days, then, keep the machine in dry and ventilated place to prolong the machine life. Please place the machine upright and do not place it in horizontal or upside down.
- When the dehumidifier needs maintenance, please contact Shun Hing Electric Service Centre Ltd. to deal with. Do not attempt to modify the appliance by yourself or repair with any unauthorized parts. Otherwise it will cause hazard and the warranty will be invalid.



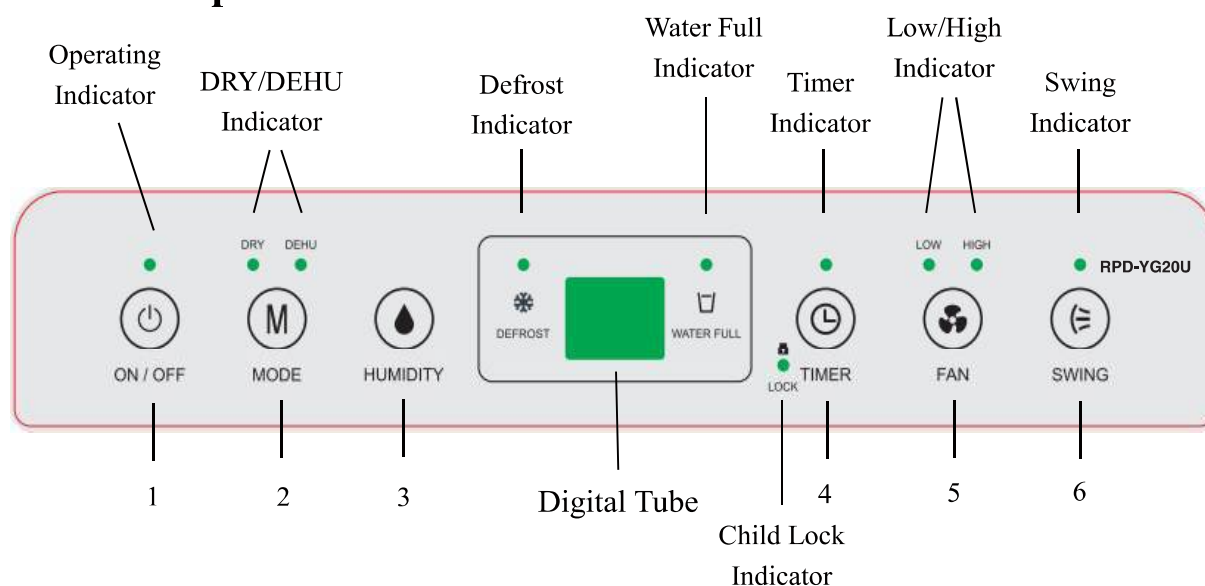

5. Operating Introduction

1. Control panel



2. The name and function of control panel

1.  **(ON/OFF):** Touch this button to switch on/off the power.
2.  **(MODE):** Touch this button to set up dry clothes mode (DRY) or dehumidify mode (DEHU)

3.  (**HUMIDITY**): Touch this button to set the desired humidity, then the digital tube will show the set humidity accordingly.
4.  (**TIMER/LOCK**): Touch this button to set the machine shutdown time. The display will show the shutdown time accordingly. Press this button for 3 seconds could turn on or off the CHILD LOCK function, the lock indicator will on or off on the control panel.
5.  (**FAN**): Touch this button to adjust the fan speed (Total is two speed). The indicator will show the set speed accordingly (low or high).
6.  (**SWING**): Touch this button to turn on or off the swing function.

3. Operating introduction

1. **Power on** : Plug in appliance and press [**ON/OFF**] button, the dehumidifier starts running, the louver opens, and the default function is dehumidify mode (DEHU). The fan speed is high. The compressor works after 3 minutes for protection purpose.

After turning off, the dehumidifier turns on again and will work as the previous setting before turning off.

Power off: When dehumidifier operates, touch [**ON/OFF**] button, the dehumidifier stop working.

2. **Mode setting button:**

Press [**MODE**] button can select dry clothes mode (DRY)、dehumidify mode (DEHU).

- ① **Dry Clothes Mode:** The DRY indicator lights up, the dehumidifier operates in the dry clothes mode, and the dehumidifier operates under the continuously dehumidify condition whatever the ambient humidity is. The fan speed cannot be set under the dry clothes mode.
- ② **Dehumidify Mode:** The DEHU indicator lights up, the dehumidifier operates under the dehumidify mode. Press [**FAN**] button can adjust the fan speed.

3. **Humidity setting:**

Press [**HUMIDITY**] button can set the desired humidity. **88*** digital tube will show CO~40%~45%~50%~55%~60%~65%~70%~CO..... in circulation. When finish the humidity setting, the digital tube will switch to show the ambient humidity from set humidity.

When the dehumidifier detects the ambient humidity is 2%RH lower than the set humidity, the dehumidifier will stop dehumidifying, the fan will keep working in low speed. When the dehumidifier detects the ambient humidity is 2%RH higher than the set humidity, the dehumidifier starts dehumidifying and the fan starts to work at set speed.

For example, the set humidity is 50%, when the machine detects the ambient humidity is $<48\%RH$, the dehumidifier will stop dehumidifying, the fan will keep working in low speed. When the dehumidifier detects the ambient humidity is $>52\%RH$, the dehumidifier starts dehumidifying and the fan starts to work at set speed. When the ambient humidity is $\leq 30\%RH$, the “LO” icon will be displayed on digital tube.

When the ambient humidity is $\geq 80\%RH$, the “HI” icon will be displayed on digital tube. CO means continuously dehumidify whatever the ambient humidity is. The dehumidifier default setting is CO when switch on the dehumidifier in the beginning.

Under the dry clothes function, the machine is running in CO mode.

4. Timer:

Press [TIMER] button, set time for auto-stop, the timer indicator lights on, the digital tube will show 0H~1H~2H~3H~4H~5H~6H~7H~8H~0H in circulation. When the digital tube shows “0H”, it means the timer for auto-stop function is cancelled and the timer icon light off. After choosing timer function, re-touch button, the digital tube will show the remaining time, then the user knows when the dehumidifier will stop automatically.

When timer function is turned on, if the water tank is full or the machine is in auto-defrost, timer is still valid, until reached the set time, the dehumidifier stops automatically.

5. Fan speed setting:

Press [FAN] speed setting button can adjust the fan speed. There are two speed (low & high) to be chosen, and the corresponding indicator will light on.

(Note: The fan speed cannot be set under the dry clothes function)

6. Swing:

Press [SWING] button, the swing indicator lights on, the louver will swing in up/down direction.

7. Child lock function:

When the machine operates, press [TIMER] button for 3 seconds to choose the child lock function, then the lock icon will light on and the control panel will be locked, all buttons are invalid; Press [TIMER] button for 3 seconds again or unplug the plug to cancel the child lock function.

8. Anion function:

When the machine turns on, the anion function turns on automatically; When the machine turns off, the anion function turns off automatically.

4. Memory Function

1. After turning off the dehumidifier, when the user turns it on again, the dehumidifier operates at the working mode before turn-off.



Noted: Timer and Lock function are inapplicable.

2. If power cuts off accidentally or unplug the power plug when operating, the machine will start to work automatically after resume power. The user should not press [ON/OFF] button again to switch on the dehumidifier, and it will work as the previous setting before shutting down.

5. Water tank full auto-stop function

When the sensor detected the water level reached the set height, the buzzer will alarm, the water full  indicator lights up, the machine will stop working and louver will close automatically. The user should empty the water tank, carry the tank back into the machine, then the machine will return back to work as the settings before water tank is full. (Note: When put back into the water tank, the compressor will wait for 3 minutes before starting to operate to protect the compressor.)

6. Auto Defrost

When the machine is working in low temperature, in order to protect cooling system, the automatic defrosting function will be activated. When the sensor detects the temperature of evaporator is lower or equal to -1°C , the compressor will run continuously for 30 minutes, then stop, the machine starts to defrost, the [Defrost] icon  lights on. When the sensor detects the temperature of evaporator is higher or equal to 2°C and the defrost time is longer or equal to 10 minutes, the auto-defrost mode stops and the compressor starts to work, the machine begins to dehumidify, the [Defrost] icon  lights off.

7. Compressor protection function

When the compressor stops working and restarts it immediately, the compressor protection function will be triggered because the cooling system pressure is not balanced. The compressor is equipped with 3 minutes' delay function; the dehumidifier will be restarted after 3 minutes.

8. High/Low temperature protection function

When the sensor detects the ambient temperature $< 3^{\circ}\text{C}$ or $> 40^{\circ}\text{C}$, the machine will stop working and the fan motor will continue to work at previous set speed.

When the sensor detect the ambient temperature $\geq 5^{\circ}\text{C}$ or $\leq 38^{\circ}\text{C}$, the machine returns to dehumidify mode. (It takes 3 minutes from the compressor stop to resume work for compressor protection purpose.)

9. Low humidity protection function

When the machine detects the ambient humidity $\leq 30\%RH$, the digital tube will show “LO”, the machine will stop dehumidifying, the fan motor will work at low speed.

When the machine detects the ambient humidity $> 35\%RH$, the digital tube will show the actual humidity, the machine will return to dehumidify. (It takes 3 minutes from the compressor stop to resume work for compressor protection purpose.)

When the machine detects the humidify $> 80\%RH$, the digital tube will show “HI”, the machine will keep working at previous set mode.

10. High temperature fan speed switch function

When the machine dehumidifies in the high temperature environment, the low speed operation of fan motor will increase the load of compressor, so when the machine dehumidifies under the high temperature environment, the fan speed will switch to the highest speed automatically. When the ambient temperature goes down, the fan speed will switch back to previous set speed.

11. Continuous drainage function

When the dehumidifier needs continuous drainage, pull out the drain hole plug, connect the drain hose with 15mm inner diameter to the drain outlet on the rear case. When the dehumidifier runs continuously, the water will drain out through drainage hose, then water tank will not contain the water, the machine can work continuously and does not shut down due to full water tank.

During continuous water draining, the drainage hose has to place flatly on the ground. The drain hose cannot be curved or cocked, otherwise, the water cannot flow out smoothly or even cannot flow.

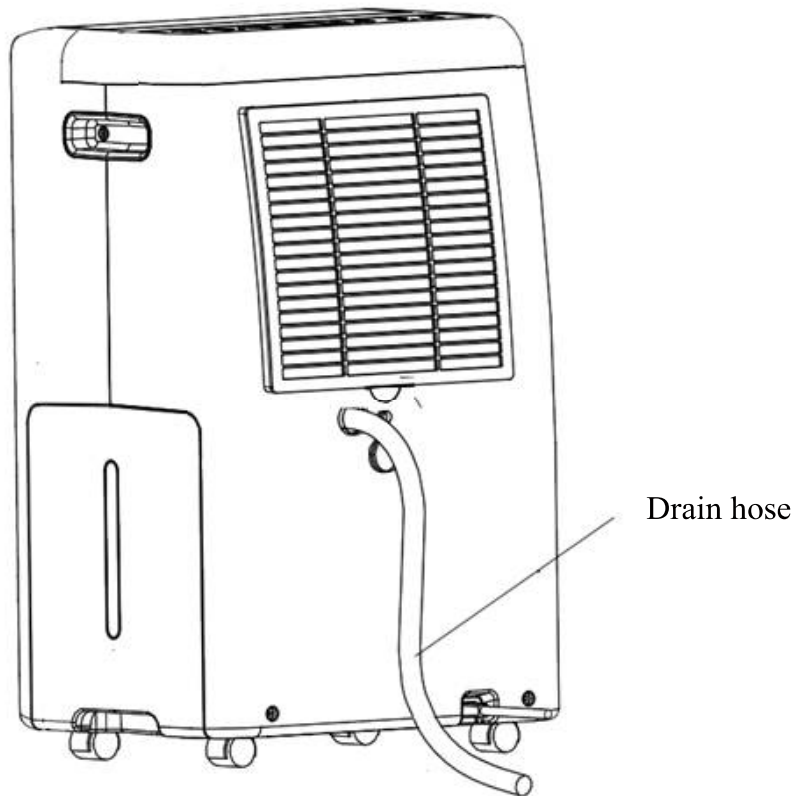

6. Troubleshooting

Before calling for repair service, please review the chart below.

Problems		Checklist
Dehumidifier does not start		<input type="checkbox"/> Make sure the power plug is inserted firmly into the socket. <input type="checkbox"/> Check the fuse/circuit breaker box. <input type="checkbox"/> Dehumidifier has reached its pre-set level or water tank is full. <input type="checkbox"/> Water tank is not in the proper position.
Poor performance of dehumidifying		<input type="checkbox"/> Do not allow enough time to remove the moisture. <input type="checkbox"/> Make sure there are no curtains, blinds or furniture blocking the front or back of the dehumidifier. <input type="checkbox"/> The ambient humidity lower than the humidity setting. <input type="checkbox"/> Check that all doors, windows and other openings are securely closed. <input type="checkbox"/> Room temperature is too low, below 5°C (41°F). <input type="checkbox"/> There is a kerosene heater or other equipment giving off water vapor in the room.
Noise during operating		<input type="checkbox"/> The air filter is clogged. <input type="checkbox"/> The unit is tilted and is not placed on floor stably. <input type="checkbox"/> The floor surface is not flat.
Frost appears on the coil		<input type="checkbox"/> This is normal. The dehumidifier has auto-defrost feature.
Water leakage		<input type="checkbox"/> Hose to connector or hose connection maybe loose. <input type="checkbox"/> Design is intended to use the water tank to collect water. The back drain hole plug maybe removed.
Error code showed on the display	C1	<input type="checkbox"/> Defrost temperature sensor maybe open-circuited or short-circuited, unplug the unit and plug it back in. <input type="checkbox"/> Evaporator temperature $\geq 40^{\circ}\text{C}$ <input type="checkbox"/> If error repeats, contact Shun Hing Electric Service Centre Ltd to check and repair.

	C2	<input type="checkbox"/> Temperature sensor maybe open-circuited, short-circuited, unplug the unit and plug it back in. <input type="checkbox"/> Temperature and humidity sensing PCB board is malfunction, unplug the unit and plug it back in. <input type="checkbox"/> Ambient temperature $\leq 0^{\circ}\text{C} \geq 40^{\circ}\text{C}$ <input type="checkbox"/> If error remains, please contact Shun Hing Electric Service Centre Ltd to check and repair.
	C8	<input type="checkbox"/> Refrigerant leakage is detected, please contact Shun Hing Electric Service Centre Ltd to check and repair.

If the above solutions cannot fix the problem, stop using immediately and contact Shun Hing Electric Service Centre Ltd to check and repair.

7.Special Avowal

1. The information above has been checked. Our company reserves the hermeneutic power to any printing errors or misunderstanding on the content.
2. If there are technical improvements on the appliance, the operation manual will be updated without any prior notice. The product appearance and color are subject to the actual appliance.
3. An electronic copy of the user manual can be emailed to the customer on requested. If necessary, please call Shun Hing Electric Works & Engineering Co., Ltd.: 2861 2767.

8. After Sales Service

For any defect, in the judgment of technician from Shun Hing Electric Service Centre Limited, caused under normal use, we are responsible for repairing or replacing parts of the said electrical appliance free of charge within one year guarantee period commencing from the date of purchase. Any defective part which has been replaced shall become our property. Guarantee service does not cover the repair or replacement of accessories, external cables, water tank or cabinet, etc. Additional charges shall be levied if services are required.

Please present the official invoice and the guarantee certificate with the sales point's chop or the redemption center's chop for free maintenance. For enquiries, please call Shun Hing Electric Service Centre Limited hotline at 2406 5666.

Free guarantee service will not be provided to the unit if: 1) it has been explicitly or implicitly modified, tampered with, altered or repaired in any way by persons other than technicians of the Company. Or 2) it has been damaged through misuse, negligence, liquid ingress or corrosion, power interruption, natural calamities or accident or external factors. Or 3) it is not a fixed installation on land. Or 4) the normal operation of the unit is affected by improper installation. Or 5) the domestic model of unit is used for industrial or commercial purpose. Or 6) the change of location or ownership of the unit and did not inform Shun Hing Electric Service Centre Limited.

9. Product Specification

Model	RPD-YG20U
Rated voltage and frequency	220-240V~ 50Hz
Dehumidifying capacity	23L / Day (30°C, 80%RH)
	13L / Day (26.7°C, 60%RH)
Consumed power	220W (26.7°C, 60%RH)
Rated power	295W (35.0°C, 90%RH)
Refrigerant	R134a / 150 g
Water tank capacity	3.8 L
Dimension (W x D x H)	355 × 252 × 567 mm



信興電工工程有限公司

SHUN HING ELECTRIC WORKS & ENGINEERING CO., LTD

辦公室：香港九龍尖沙咀東部麼地道 67 號半島中心 9 樓

OFFICE: 9/F, PENINSULA CENTRE, 67 MODY ROAD, TSIMSHATSUI EAST, KOWLOON, HONG KONG

電話 TEL: (852) 2861 2767 傳真 FAX: (852) 2865 6706

網址 WEBSITE: www.rasonic.com 電郵 EMAIL: shew@shunhinggroup.com

保養及維修 MAINTENANCE AND REPAIR SERVICE

信興電器服務中心有限公司

SHUN HING ELECTRIC SERVICE CENTRE LTD.

辦公室：香港新界葵涌勝耀街 2 號信興中心 11 樓

OFFICE: 11TH FLOOR, SHUN HING CENTRE, 2 SHING YIU STREET, KWAI CHUNG, NEW TERRITORIES, HONG KONG

電話 TEL: (852) 2406 5666

傳真 FAX: (852) 2408 0316

網址 WEBSITE: www.shesc.com

消耗品/附件銷售熱線 CONSUMABLES/ ACCESSORIES SALES HOTLINE

電話 TEL: (852) 2406 5666

客戶服務中心 CUSTOMER SERVICE CENTRES

香港新界葵涌勝耀街 2 號信興中心 1 樓

1ST FLOOR, SHUN HING CENTRE, 2 SHING YIU STREET, KWAI CHUNG, NEW TERRITORIES, HONG KONG

電話 TEL: (852) 2406 5439

傳真 FAX: (852) 2408 1389

澳門慕拉士大馬路 193-199 號南嶺工業大廈 5 樓 I 座

AVENIDA DE VENCESLAU DE MORAIS, NO. 193-199, 5 ANDAR-I, EDF. INDUSTRIAL NAM LENG, MACAU

電話 TEL: (853) 2836 2928

傳真 FAX: (853) 2833 6405

有關最新之客戶服務中心資訊，請參閱信興服務中心網址 www.shesc.com 或致電維修服務熱線查詢。

For the latest information of customer service centres, please visit www.shesc.com or call us at our hotline.